



EMERSON[™]
Industrial Automation



Installation Guide

Digitax *ST*

Part Number: 0475-0000-02
Issue: 2



**CONTROL
TECHNIQUES**

www.controltechniques.com

General Information

The manufacturer accepts no liability for any consequences resulting from inappropriate, negligent or incorrect installation or adjustment of the optional parameters of the equipment or from mismatching the variable speed drive with the motor.

The contents of this guide are believed to be correct at the time of printing. In the interests of commitment to a policy of continuous development and improvement, the manufacturer reserves the right to change the specification of the product or its performance, or the content of the guide without notice.

All rights reserved. No parts of this guide may be reproduced or transmitted in any form or by any means, electrical or mechanical including, photocopying, recording or by an information storage or retrieval system, without permission in writing from the publisher.

Drive software version

This product is supplied with the latest version of user-interface and machine control software. If this product is to be used in a new or existing system with other drives, there may be some differences between their software and the software in this product. These differences may cause the product to function differently. This may also apply to drives returned from the Control Techniques Service Centre.

If there is any doubt, please contact your local Control Techniques Drive Centre or Distributor.

Environmental Statement

Control Techniques is committed to minimising the environmental impacts of its manufacturing operations and of its products throughout their life cycle. To this end, we operate an Environmental Management System (EMS) which is certified to the International Standard ISO 14001. Further information on the EMS, our Environment Policy and other relevant information is available on request, or can be found at www.greendrives.com.

The electronic variable speed drives manufactured by Control Techniques have the potential to save energy and (through increased machine/process efficiency) reduce raw material consumption and scrap throughout their long working lifetime. In typical applications, these positive environmental effects far outweigh the negative impacts of product manufacture and end-of-life disposal.

Nevertheless, when the products eventually reach the end of their useful life, they can very easily be dismantled into their major component parts for efficient recycling. Many parts snap together and can be separated without the use of tools, while other parts are secured with conventional screws.

Virtually all parts of the product are suitable for recycling.

Product packaging is of good quality and can be re-used. Large products are packed in wooden crates, while smaller products come in strong cardboard cartons which themselves have a high-recycled fibre content. If not re-used, these containers can be recycled. Polythene, used on the protective film and bags from wrapping product, can be recycled in the same way. Control Techniques' packaging strategy favours easily recyclable materials of low environmental impact, and regular reviews identify opportunities for improvement.

When preparing to recycle or dispose of any product or packaging, please observe local legislation and best practice.

Contents

1	Safety Information	5
1.1	Warnings, Cautions and Notes	5
1.2	Electrical safety - general warning	5
1.3	System design and safety of personnel	5
1.4	Environmental limits	6
1.5	Compliance with regulations	6
1.6	Motor	6
1.7	Adjusting parameters	6
1.8	Electrical installation	6
2	Introduction	8
2.1	Features of the drive	9
2.2	Items supplied with the drive	9
3	Mechanical Installation	11
3.1	Drive	11
3.2	Braking	13
3.3	External EMC filter	14
4	Electrical Installation	15
4.1	Power terminal connections	15
4.2	Ground leakage	17
4.3	EMC	18
4.4	Control terminals	21
4.5	Recommended simple start-up	27

Declaration of Conformity

Control Techniques Ltd
The Gro
Newtown
Powys
UK
SY16 3BE

DST1201	DST1202	DST1203	DST1204	
DST1401	DST1402	DST1403	DST1404	DST1405

The AC variable speed drive products listed above have been designed and manufactured in accordance with the following European harmonised standards:

EN 61800-5-1	Adjustable speed electrical power drive systems - safety requirements - electrical, thermal and energy
EN 61800-3	Adjustable speed electrical power drive systems. EMC product standard including specific test methods
EN 61000-6-2	Electromagnetic compatibility (EMC). Generic standards. Immunity standard for industrial environments
EN 61000-6-4	Electromagnetic compatibility (EMC). Generic standards. Emission standard for industrial environments
EN 61000-3-2	Electromagnetic compatibility (EMC), Limits, Limits for harmonic current emissions (equipment input current <16A per phase)
EN 61000-3-3	Electromagnetic compatibility (EMC), Limits, Limitation of voltage fluctuations and flicker in low-voltage supply systems for equipment with rated current <16A

EN 61000-3-2: Applicable where input current <16A. No limits apply for professional equipment where input power >1kW.

These products comply with the Low Voltage Directive 2006/95/EC, the Electromagnetic Compatibility (EMC) Directive 89/336/EEC and the CE Marking Directive 93/68/EEC.

W. Drury
Executive VP Technology
Date: 2nd May 2007



These electronic drive products are intended to be used with appropriate motors, controllers, electrical protection components and other equipment to form complete end products or systems. Compliance with safety and EMC regulations depends upon installing and configuring drives correctly, including using the specified input filters. The drives must be installed only by professional assemblers who are familiar with requirements for safety and EMC. The assembler is responsible for ensuring that the end product or system complies with all the relevant laws in the country where it is to be used. Refer to the User Guide. An EMC Data Sheet is also available giving detailed EMC information.

1 Safety Information

1.1 Warnings, Cautions and Notes



A **Warning** contains information, which is essential for avoiding a safety hazard.



A **Caution** contains information, which is necessary for avoiding a risk of damage to the product or other equipment.

NOTE

A **Note** contains information, which helps to ensure correct operation of the product.

1.2 Electrical safety - general warning

The voltages used in the drive can cause severe electrical shock and/or burns, and could be lethal. Extreme care is necessary at all times when working with or adjacent to the drive.

Specific warnings are given at the relevant places in this guide.

1.3 System design and safety of personnel

The drive is intended as a component for professional incorporation into complete equipment or a system. If installed incorrectly, the drive may present a safety hazard.

The drive uses high voltages and currents, carries a high level of stored electrical energy, and is used to control equipment which can cause injury.

Close attention is required to the electrical installation and the system design to avoid hazards either in normal operation or in the event of equipment malfunction. System design, installation, commissioning and maintenance must be carried out by personnel who have the necessary training and experience. They must read this safety information and this guide carefully.

The STOP and SAFE TORQUE OFF functions of the drive do not isolate dangerous voltages from the output of the drive or from any external option unit. The supply must be disconnected by an approved electrical isolation device before gaining access to the electrical connections.

With the sole exception of the SAFE TORQUE OFF function, none of the drive functions must be used to ensure safety of personnel, i.e. they must not be used for safety-related functions.

Careful consideration must be given to the functions of the drive which might result in a hazard, either through their intended behaviour or through incorrect operation due to a fault. In any application where a malfunction of the drive or its control system could lead to or allow damage, loss or injury, a risk analysis must be carried out, and where necessary, further measures taken to reduce the risk - for example, an over-speed protection device in case of failure of the speed control, or a fail-safe mechanical brake in case of loss of motor braking.

The SAFE TORQUE OFF function has been approved¹ as meeting the requirements of EN954-1 category 3 for the prevention of unexpected starting of the drive. It may be used in a safety-related application. The system designer is responsible for ensuring that the complete system is safe and designed correctly according to the relevant safety standards.

¹Independent approval by BGIA is pending.

1.4 Environmental limits

Instructions regarding transport, storage, installation and use of the drive must be complied with, including the specified environmental limits. Drives must not be subjected to excessive physical force. Refer to the *Technical Data Guide*.

1.5 Compliance with regulations

The installer is responsible for complying with all relevant regulations, such as national wiring regulations, accident prevention regulations and electromagnetic compatibility (EMC) regulations. Particular attention must be given to the cross-sectional areas of conductors, the selection of fuses or other protection, and protective ground (earth) connections.

Within the European Union, all machinery in which this product is used must comply with the following directives:

98/37/EC: Safety of machinery.

89/336/EEC: Electromagnetic Compatibility.

1.6 Motor

Ensure the motor is installed in accordance with the manufacturer's recommendations. Ensure the motor shaft is not exposed.

The values of the motor parameters set in the drive affect the protection of the motor. The default values in the drive should not be relied upon.

It is essential that the correct value is entered in Pr **0.46 Motor rated current**. This affects the thermal protection of the motor.

1.7 Adjusting parameters

Some parameters have a profound effect on the operation of the drive. They must not be altered without careful consideration of the impact on the controlled system.

Measures must be taken to prevent unwanted changes due to error or tampering.

1.8 Electrical installation

1.8.1 Electric shock risk

The voltages present in the following locations can cause severe electric shock and may be lethal:

- AC supply cables and connections
- DC bus, dynamic brake cables and connections
- Output cables and connections
- Many internal parts of the drive, and external option units

Unless otherwise indicated, control terminals are single insulated and must not be touched.

1.8.2 Isolation device

The AC supply must be disconnected from the drive using an approved isolation device before any cover is removed from the drive or before any servicing work is performed.

1.8.3 STOP function

The STOP function does not remove dangerous voltages from the drive, the motor or any external option units.

1.8.4 Stored charge

The drive contains capacitors that remain charged to a potentially lethal voltage after the AC supply has been disconnected. If the drive has been energised, the AC supply must be isolated at least ten minutes before work may continue.

Normally, the capacitors are discharged by an internal resistor. Under certain, unusual fault conditions, it is possible that the capacitors may fail to discharge, or be prevented from being discharged by a voltage applied to the output terminals. If the drive has failed in a manner that causes the display to go blank immediately, it is possible the capacitors will not be discharged. In this case, consult Control Techniques or their authorised distributor.

1.8.5 Equipment supplied by plug and socket

Special attention must be given if the drive is installed in equipment which is connected to the AC supply by a plug and socket. The AC supply terminals of the drive are connected to the internal capacitors through rectifier diodes which are not intended to give safety isolation. If the plug terminals can be touched when the plug is disconnected from the socket, a means of automatically isolating the plug from the drive must be used (e.g. a latching relay).

1.8.6 Permanent magnet motors

Permanent magnet motors generate electrical power if they are rotated, even when the supply to the drive is disconnected. If that happens then the drive will become energised through its motor terminals.

If the motor load is capable of rotating the motor when the supply is disconnected, then the motor must be isolated from the drive before gaining access to any live parts.

2 Introduction

The Digitax ST family of servo drives are available with four levels of intelligence:

- Digitax ST Base
- Digitax ST Indexer
- Digitax ST Plus
- Digitax ST EZMotion

The Digitax ST Base drive operates in velocity or torque modes and is designed to operate with a centralised motion controller or as a standalone drive.

The Digitax ST Indexer drive performs point-to-point motion profiling including relative, absolute, rotary plus, rotary minus, registration and homing motion. The Digitax ST Indexer will operate as a single standalone system controller. Alternatively, the Digitax ST Indexer can form part of a distributed system where commands are sent over a fieldbus or through digital input/output signals.

The Digitax ST Plus drive offers all the features available on the Digitax ST Indexer drive with the addition of performing complex motion as a single axis or synchronised to a reference axis. This offers digital lock and electronic camming via a virtual master reference.

The Digitax ST EZMotion drive is part of the Motion Made Easy family of servo drives and allows the user to create programs to sequence motion, I/O control, and other machine operations in one environment. Digitax ST EZMotion also supports advanced functions such as a Position Capture Object, Multiple Profile Summation, Queuing, and Program Multitasking.

All variants provide a SAFE TORQUE OFF function. This function is identical to that referred to as "SECURE DISABLE" in the Control Techniques Unidrive SP product range. The name has been changed in accordance with draft standard prEN 61800-5-2 (future IEC 61800-5-2, EN 61800-5-2)

Figure 2-1 Model code explanation

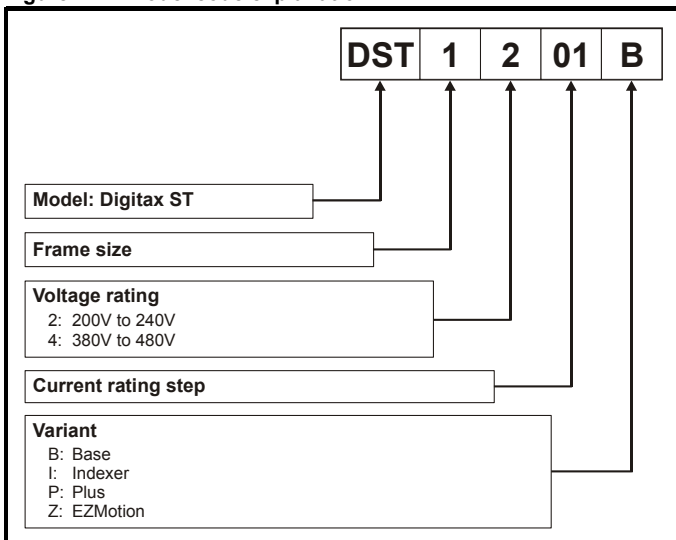

2.1 Features of the drive

Figure 2-1 Features of the drive

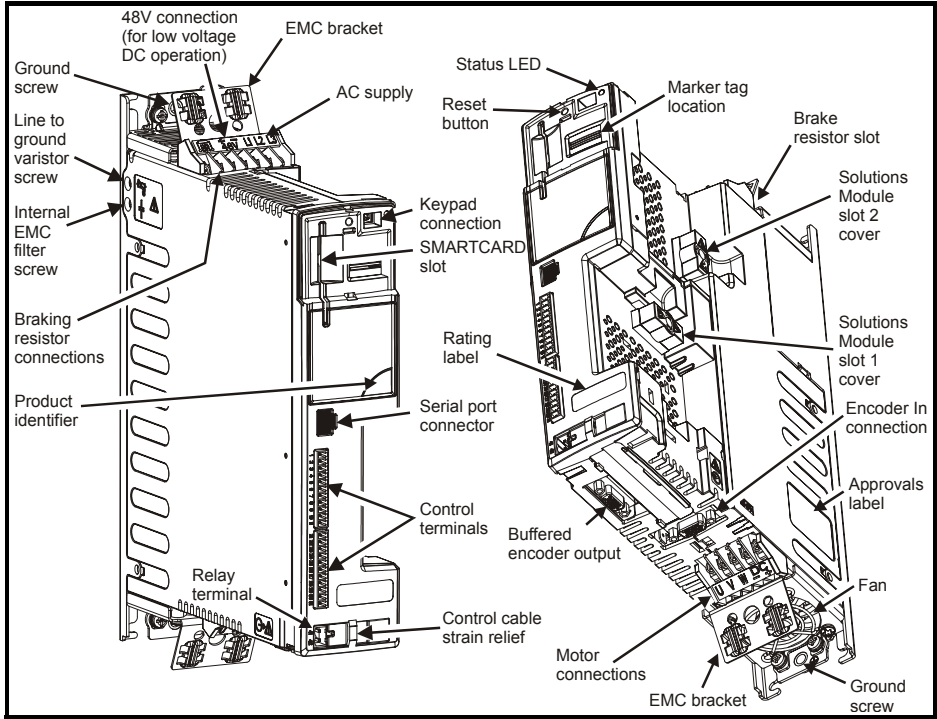

NOTE

The drive is supplied with a SMARTCARD installed. Do not remove until after first power-up, as defaults are stored on the SMARTCARD.



Static precautions must be taken when removing the Solutions Module slot covers.

2.2 Items supplied with the drive

The drive is supplied with the following items:

- Installation Guide
- SMARTCARD
- Safety Information booklet
- Certificate of Quality
- CD ROM containing all appropriate drive and option module documentation, and software tools

An accessory box containing the items illustrated in Figure 2-2 is also provided.

Figure 2-2 Accessory box contents

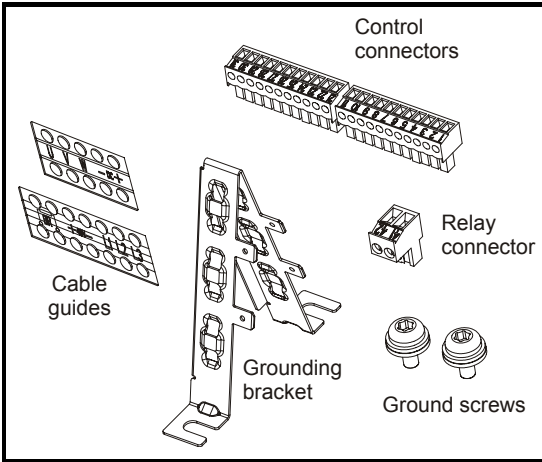

3 Mechanical Installation



Enclosure

The drive is intended to be mounted in an enclosure which prevents access except by trained and authorized personnel, and which prevents the ingress of contamination. It is designed for use in an environment classified as pollution degree 2 in accordance with IEC 60664-1. This means that only dry, non-conducting contamination is acceptable.

3.1 Drive

The drive complies with the requirements of IP20 as standard.

Figure 3-1 Dimensions

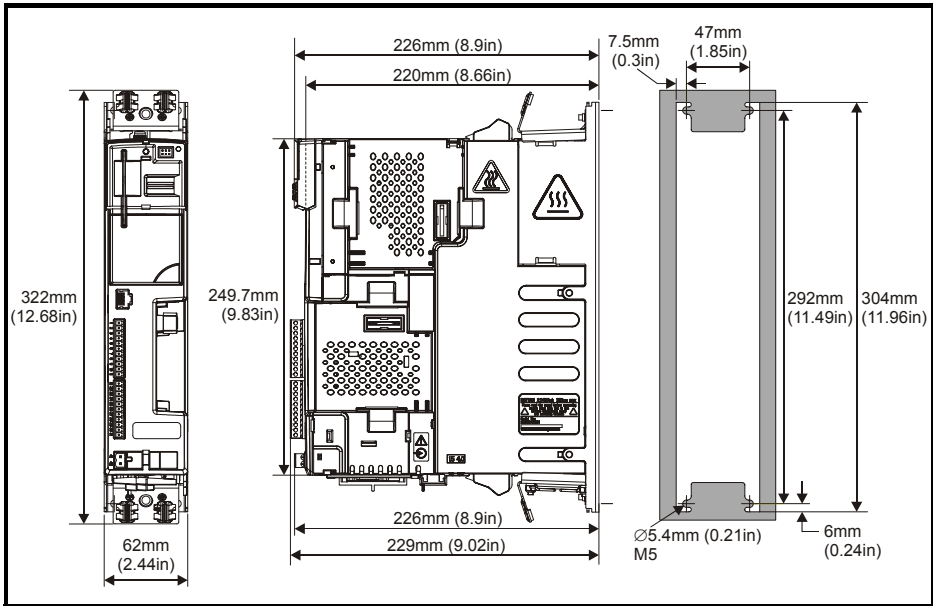
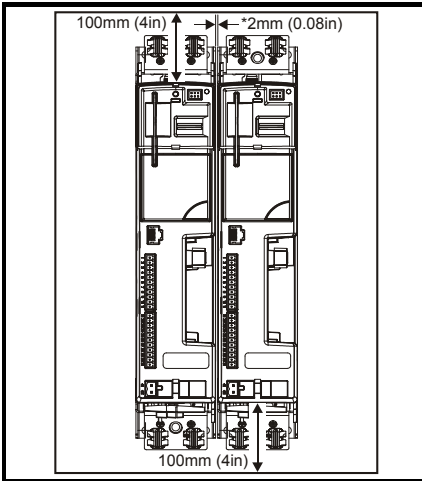

Figure 3-2 Minimum mounting clearances



*2mm clearance between drives to allow for mechanical tolerance.

Digitax ST can be mounted using a DIN rail, either fixed at the top or the bottom of the drive (as illustrated in Figure 3-3). Two screws are required to fix the drive to the backplate at the opposite end to the DIN rail.

Figure 3-3 DIN rail mounting

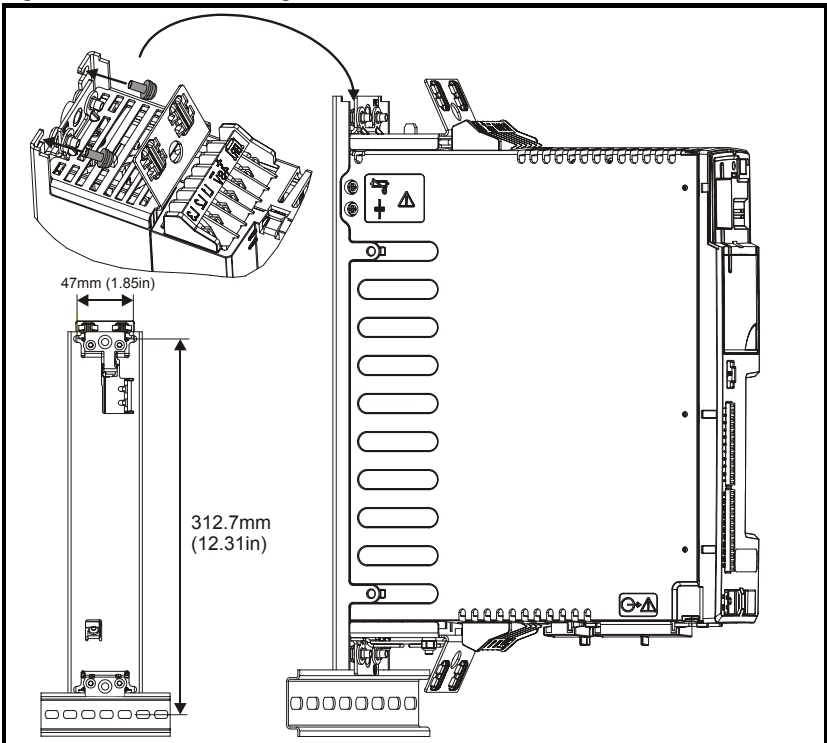

3.2 Braking

3.2.1 Optional internal braking resistor

Figure 3-4 Fitting an optional internal braking resistor (top view of drive)

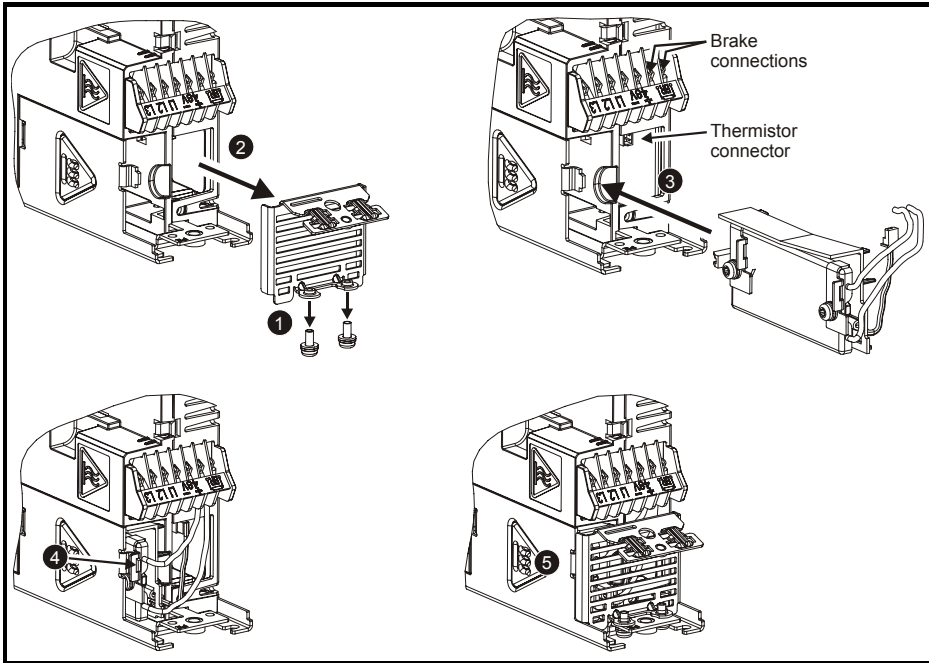

1. Remove screws
2. Remove grill
3. Fit the optional internal braking resistor in the slot provided and electrically connect the braking resistor (connections shown in Figure 4-1 on page 15)
4. Locate the braking resistor onto the drive tab
5. Refit the grill and mounting screws by reversing the procedure in points 1 and 2

3.2.2 Optional external braking resistor

If using an external braking resistor, the following Warning must be adhered to:



Braking resistor: High temperatures and overload protection

Braking resistors can reach high temperatures. Locate braking resistors so that damage cannot result. Use cable having insulation capable of withstanding the high temperatures.

3.3 External EMC filter

There are three variants of external EMC filters available for the drive.

Table 3-1 Drive EMC filter details

Drive	No. of phases	CT part no.	Schaffner part no.
DST120X	1	4200-6000	FS23072-19-07
DST120X	3	4200-6001	FS23073-17-07
DST140X	3	4200-6002	FS23074-11-07

Figure 3-5 Bookcase mounting

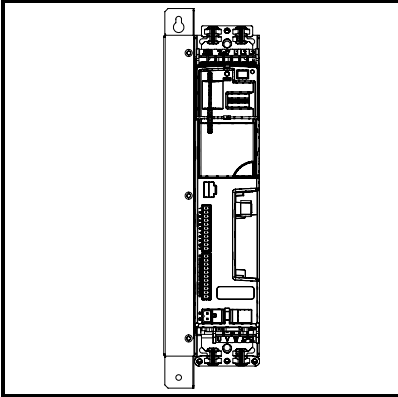

Figure 3-6 Footprint mounting

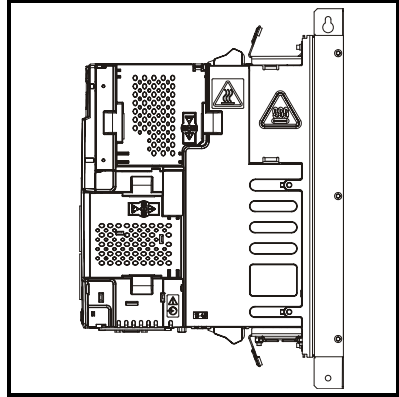

Figure 3-7 Optional external EMC filter dimensions (all variants)

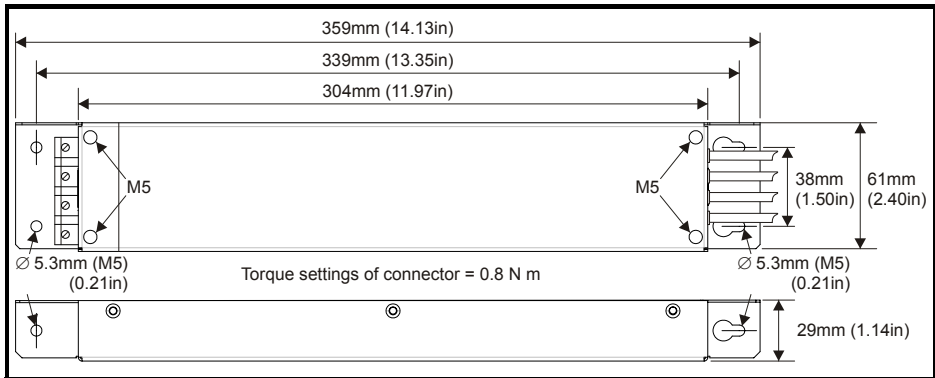

Figure 3-7 shows a 3 phase filter. For a single phase filter, there are only 3 input terminals (L1, N, ground) and 3 output cables (L1, N, ground).

4 Electrical Installation

4.1 Power terminal connections

Figure 4-1 Power terminal connections

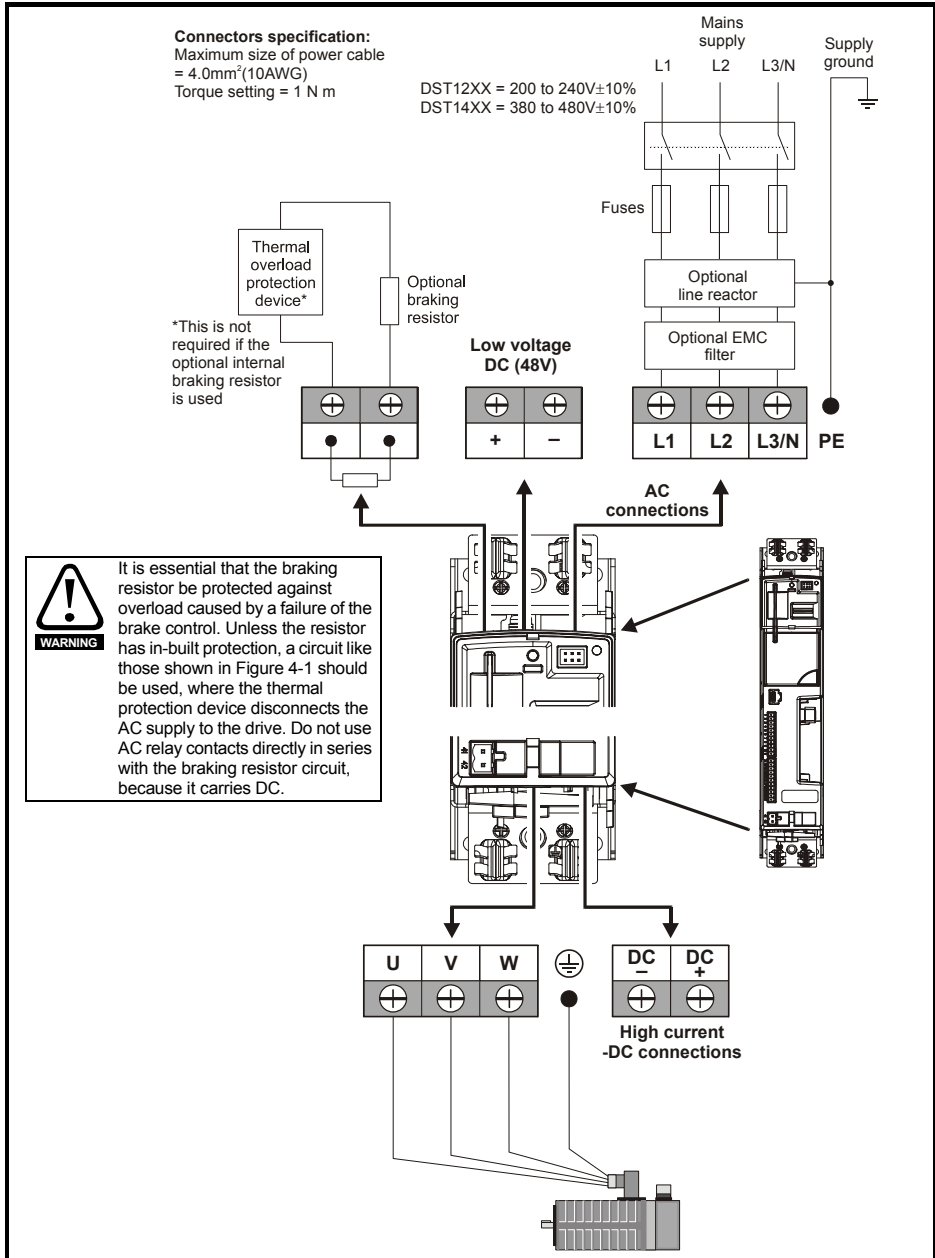

Table 4-1 Fuse ratings and cable sizes

Model	No of input phases	Typical input current A	Maximum continuous input current A	Fuse rating		Cable size			
				IEC class gG	Class CC	Input		Output	
						mm ²	AWG	mm ²	AWG
DST1201	1		3.1	6	10	0.75	16	0.75	24
DST1202	1		6.4	10	10	1	16	0.75	22
DST1203	1		8.6	16	15	2.5	14	0.75	20
DST1204	1		11.8	16	20	2.5	12	0.75	18
DST1201	3	3.1	3.5	6	10	0.75	16	0.75	24
DST1202	3	6.4	7.3	10	10	1	16	0.75	22
DST1203	3	8.6	9.4	16	15	2.5	14	0.75	20
DST1204	3	11.8	13.4	16	20	2.5	12	0.75	18
DST1401	3	2.6	2.8	4	10	0.75	16	0.75	24
DST1402	3	4.2	4.3	6	10	0.75	16	0.75	24
DST1403	3	5.9	6.0	8	10	0.75	16	0.75	22
DST1404	3	7.9	8.0	10	10	1	16	0.75	20
DST1405	3	9.9	9.9	10.0	12	1.5	14	0.75	18
Control cable						≥0.5	20		

Use 105°C (221°F) (UL 60/75°C temp rise) PVC-insulated cable with copper conductors having a suitable voltage rating, for the following power connections:

- AC supply to external EMC filter (when used)
- AC supply (or external EMC filter) to drive
- Drive to motor
- Drive to braking resistor
- When operating in ambient >45°C UL 75°C cable should be used.

Cable sizes are given for guidance only and may be changed depending on the application and the method of installation of the cables.

The mounting and grouping of cables affect their current capacity, in some cases a larger cable is required to avoid excessive temperature or voltage drop.

Input cable sizes should generally be regarded as a minimum, since they have been selected for co-ordination with the recommended fuses.

Output cable sizes assume that the maximum motor current matches that of the drive.

Where a motor of reduced rating is used the cable rating may be chosen to match that of the motor.

To ensure that the motor and cable are protected against overload, the drive must be programmed with the correct motor rated current.

The terminals are designed for a maximum cable size of 4.0mm² (minimum 26 AWG).

Where more than one cable per terminal is used the combined diameters should not exceed the maximum.

The terminals are suitable for both solid and stranded wires.

An MCB (miniature circuit breaker) may be used in place of fuses under the following conditions:

- The fault-clearing capacity must be sufficient for the installation
- The I²T rating of the MCB must be less than or equal to that of the fuse rating listed above



Fuses/MCB

The AC supply to the drive must be installed with suitable protection against overload and short circuits. Failure to observe this requirement will cause risk of fire.



The drive must be grounded by a conductor sufficient to carry the prospective fault current in the event of a fault. See also the warning in section 4.2 *Ground leakage* relating to ground leakage current.

4.2 Ground leakage

The ground leakage current depends upon whether the internal EMC filter is installed. The drive is supplied with the filter installed. Instructions for removing the internal filter are given in Figure 4-2.

With the internal EMC filter fitted the ground leakage current is as follows:

Table 4-2 Ground leakage current with internal EMC filter fitted

Model	3 phase Star ground	3 phase Delta ground	1 phase
	mA		
DST120X at 220V	4	10	3
DST140X at 400V	12	40	

NOTE The above leakage current is just the leakage current of the drive with the internal EMC filter connected and does not take into account any leakage currents of the motor or motor cable.

With internal EMC filter removed the ground leakage current = <1mA.

NOTE In both cases, there is an internal voltage surge suppression device connected to ground. Under normal circumstances, this carries negligible current.



When the internal EMC filter is installed, the leakage current is high. In this case, a permanent fixed ground connection must be provided with a cross sectional area equal to 10mm².

4.2.1 Use of residual current device (RCD)

There are three common types of ELCB / RCD:

1. AC - detects AC fault currents
2. A - detects AC and pulsating DC fault currents (provided the DC current reaches zero at least once every half cycle)
3. B - detects AC, pulsating DC and smooth DC fault currents
 - Type AC should never be used with drives
 - Type A can only be used with single phase drives
 - Type B must be used with three phase drives



Only type B ELCB / RCD are suitable for use with 3 phase inverter drives.

If an external EMC filter is used, a delay of at least 50ms should be incorporated to ensure spurious trips are not seen. The leakage current is likely to exceed the trip level if all of the phases are not energised simultaneously.

4.3 EMC

4.3.1 Internal EMC filter

It is recommended that the internal EMC filter is kept in place unless there is a specific reason for removing it.

Special attention is required when using a DST120X model on an ungrounded supply (IT supply). In the event of a ground fault in the motor circuit the drive may not trip and the filter could be overstressed. In this case, either the filter must be removed or additional independent motor ground fault protection must be provided.

The internal EMC filter reduces radio-frequency emissions into the mains supply. Where the motor cable is short, it permits the requirements of EN61800-3 to be met for the second environment.

For longer motor cables, the filter continues to provide a useful reduction in emission level, and when used with any length of shielded cable up to the limit for the drive, it is unlikely that nearby industrial equipment will be disturbed. It is recommended that the filter be used in all applications unless the ground leakage current is unacceptable or the above conditions are true.



WARNING

The supply must be disconnected before removing the internal EMC filter or line to ground varistor screws.

Figure 4-2 Removing the internal EMC filter and line to ground varistors

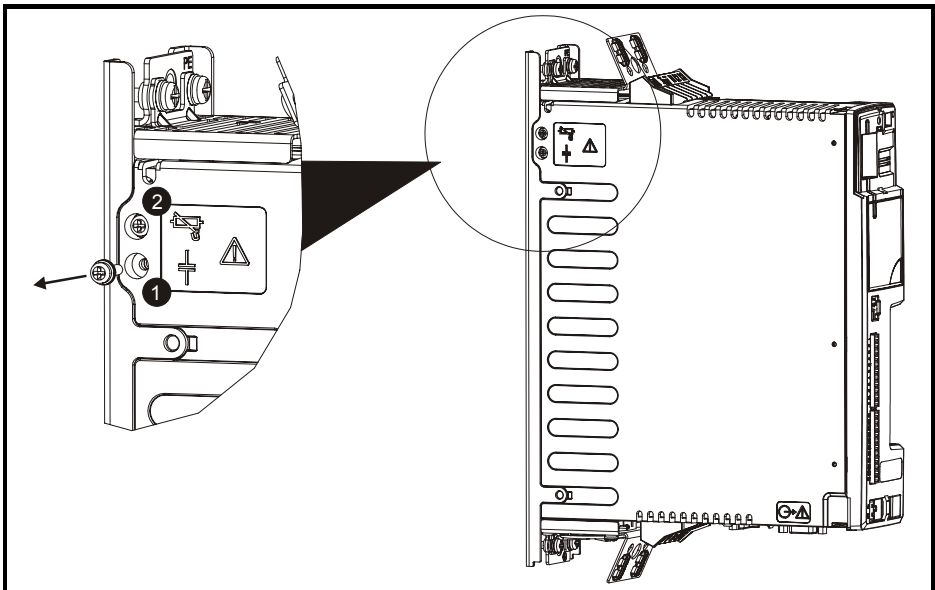

1. Internal EMC filter. Remove the bottom screw as shown.
2. Line to ground varistors. Remove the top screw as shown.

NOTE

The line to ground varistors should only be removed in special circumstances.

4.3.2 Further EMC precautions

Further EMC precautions are required if more stringent EMC emission requirements apply:

- Operation in the first environment of EN 61800-3
- Conformity to the generic emission standards
- Equipment which is sensitive to electrical interference operating nearby

In this case it is necessary to use:

- The optional external EMC filter
- A shielded motor cable, with shield clamped to the grounded metal panel
- A shielded control cable, with shield clamped to the grounded metal panel via the grounding bracket

NOTE

It is not necessary to remove the external EMC filter when using an IT supply.

4.3.3 Recommended cable management

Figure 4-3 Drive cable clearances

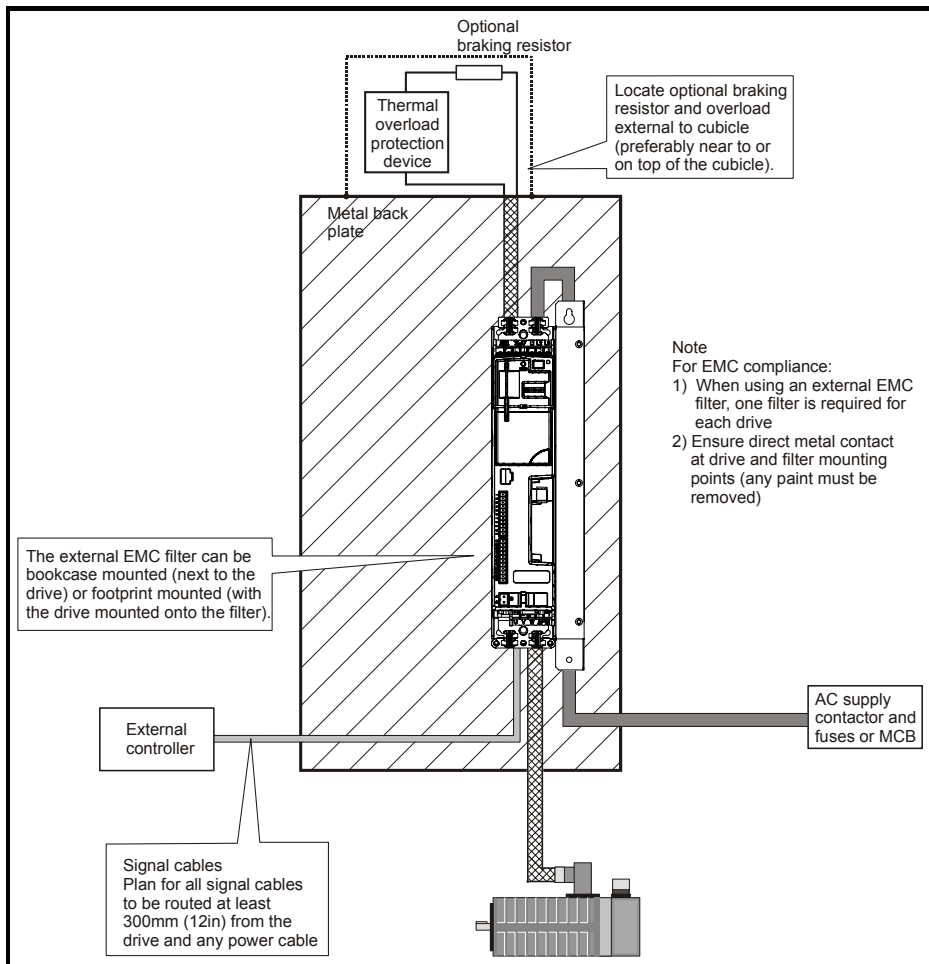

Figure 4-4 Top of drive

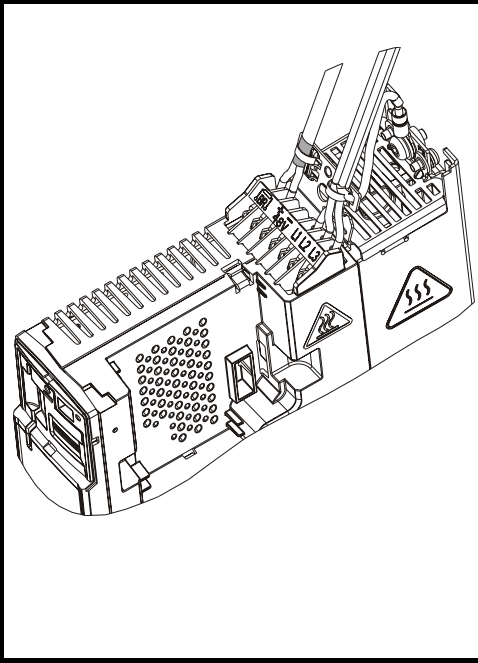
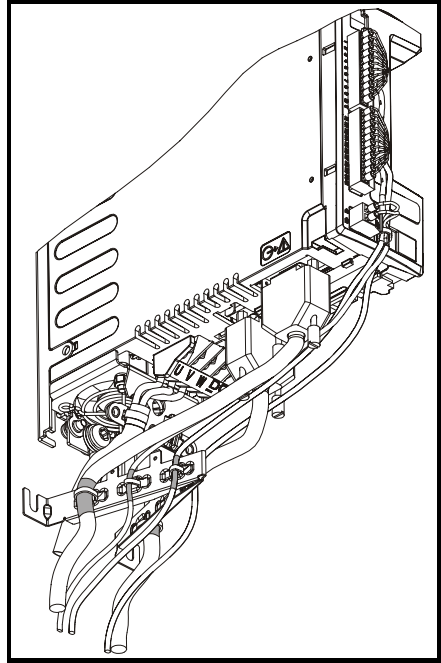

Figure 4-5 Bottom of drive



Grounding bracket and drive to be directly connected to a grounded backplate.

NOTE

The grounding bracket can remain mounted when the drive is removed.

Figure 4-6 Multiple drives with single grounding bracket

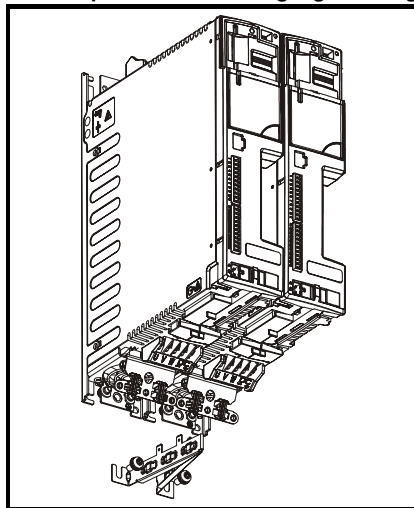

If fitting multiple drives, one grounding bracket can be used for two drives.

4.4 Control terminals



The control circuits are isolated from the power circuits in the drive by basic insulation (single insulation) only. The installer must ensure that the external control circuits are insulated from human contact by at least one layer of insulation (supplementary insulation) rated for use at the AC supply voltage.

Figure 4-7 Default terminal functions

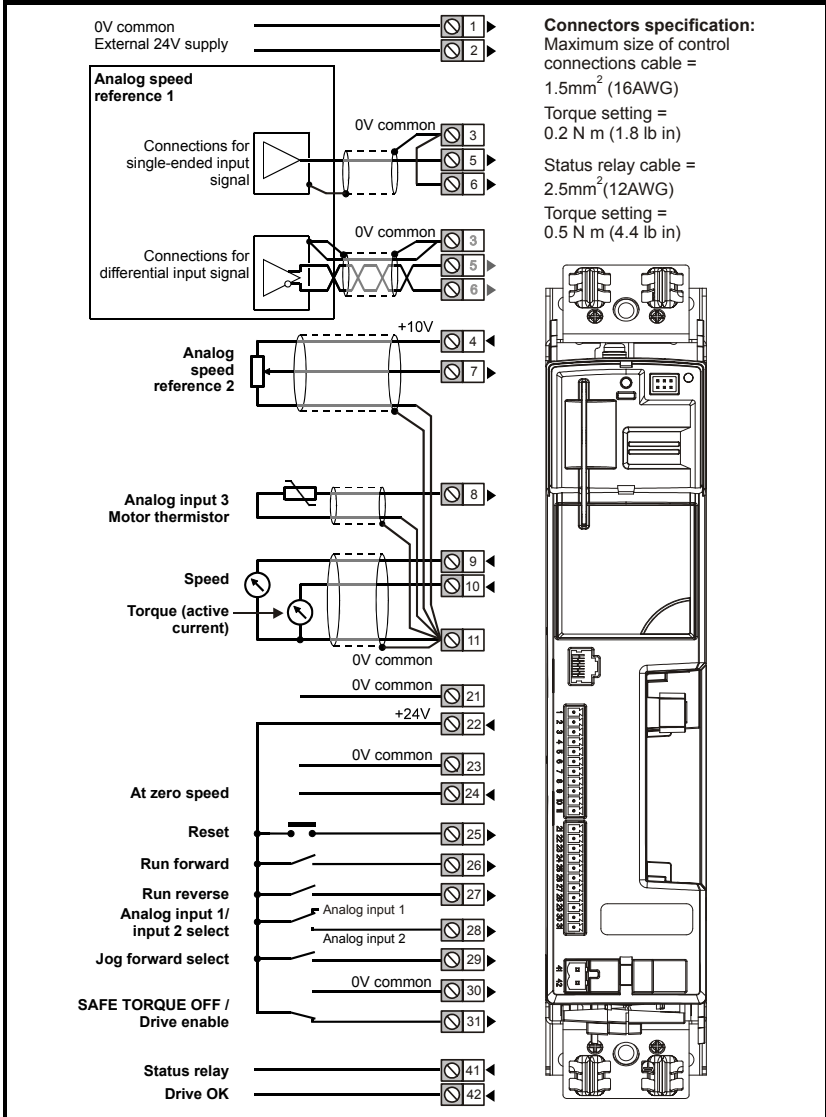

For control terminal specification, refer to the *Technical Data Guide*.

NOTE

If terminal 31 is used as a **SAFE TORQUE OFF** function, the cable must be shielded or segregated.

4.4.1 Encoder connections

Before using the encoder connectors for the first time, the break-outs need removing as shown in Figure 4-8.

Figure 4-8 Access to encoder connections

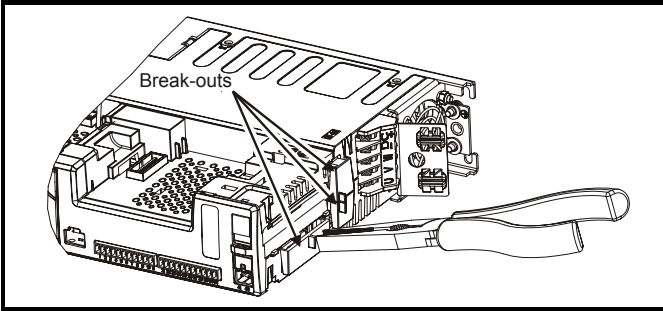

After removing the break-outs, ensure that the ground tab is connected to ground.

NOTE Do not remove break-out if the connections are not required.

Figure 4-9 Connecting the encoder ground tab to the EMC bracket

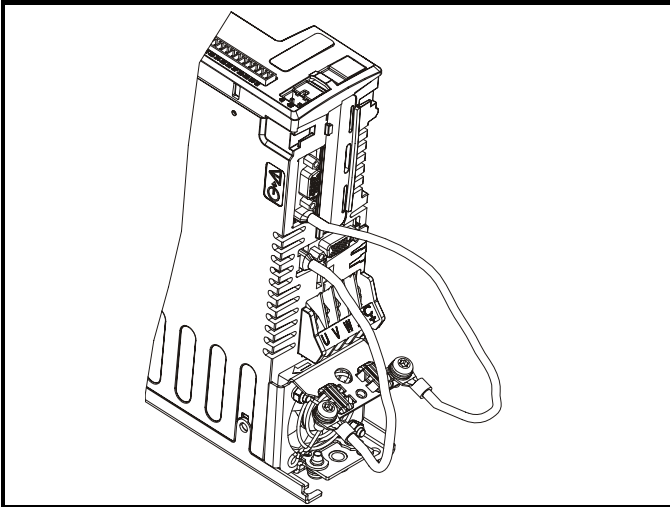

NOTE The size of the connecting cable between the encoder ground tab and the EMC bracket should be equal to the input cable.

Recommended cable

The recommended cable for feedback signals are shielded twisted pairs, shielded with an overall shield as shown in Figure 4-10

Figure 4-10 Feedback Cable, Twisted Pairs

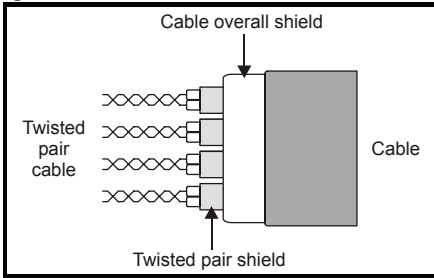

Using this type of cable also allows for the connection of the outer shield to ground and the inner shields to 0V alone at both drive and encoder end, when required.

NOTE

Ensure that feedback cables are kept as far away as possible from power cables and avoid parallel routing.

Figure 4-11 Feedback cable connections

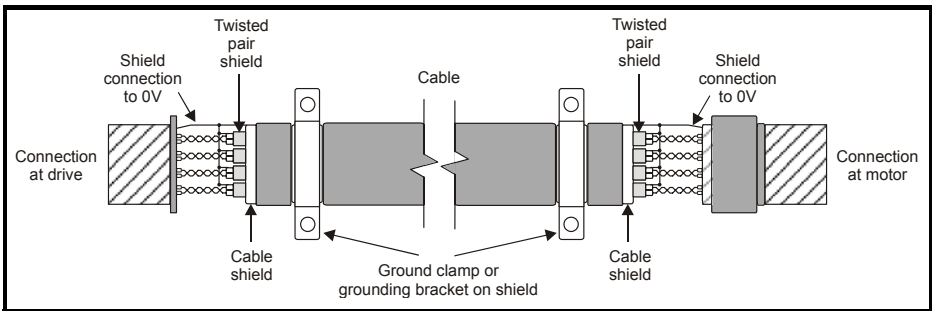
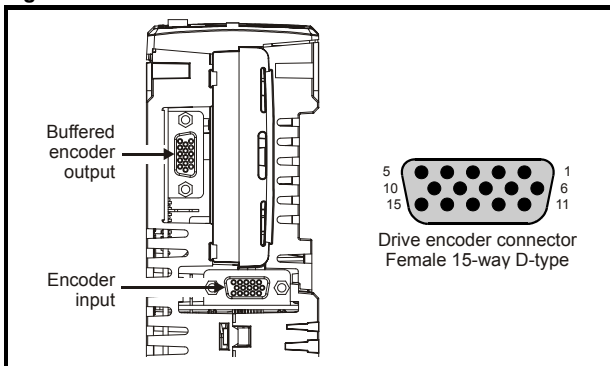

Figure 4-12 Location of encoder connectors on underside of drive



Drive encoder input converter connector

A 15-way D-type converter is available to provide a screw terminal interface for encoder wiring, and a spade terminal for the shield.

Figure 4-13 Drive encoder input converter connector

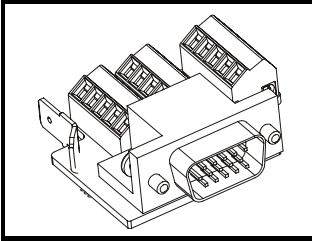

If using the drive encoder input converter connector protection to at least IP2X must be provided for the connector.

Table 4-3 Encoder In connector details

Term.	Setting of Pr 3.38											
	Ab (0)	Fd (1)	Fr (2)	Ab.SErVO (3)	Fd.SErVO (4)	Fr.SErVO (5)	SC (6)	SC.HiPEr (7)	EndAt (8)	SC.EndAt (9)	SSI (10)	SC.SSI (11)
1	A	F	F	A	F	F		Cos		Cos		Cos
2	A\	F\	F\	A\	F\	F\		Cosref		Cosref		Cosref
3	B	D	R	B	D	R		Sin		Sin		Sin
4	B\	D\	R\	B\	D\	R\		Sinref		Sinref		Sinref
5	Z*							Encoder input - Data (input/output)				
6	Z*							Encoder input - Data\ (input/output)				
7				U								
8				U\								
9				V								
10				V\								
11				W								
12	W\							Encoder input - Clock (output)				
								Encoder input - Clock\ (output)				
13	+V**											
14	0V common											
15	th***											
Shell	0V common											

* Marker pulse is optional

** The encoder supply is selectable through parameter configuration to 5Vdc, 8Vdc and 15Vdc

*** Terminal 15 is a parallel connection to T8 analog input 3. If this is to be used as a thermistor input, ensure that Pr 7.15 is set to 'th.sc' (7), 'th' (8) or 'th.diSP' (9)

Table 4-4 Simulated encoder output connector details

Term.	Setting of Pr 3.54				
	Ab (0)	Fd (1)	Fr (2)	Ab.L (3)	Fd.L (4)
1	A	F	F	A	F
2	A\<	F\<	F\<	A\<	F\<
3	B	D	R	B	D
4	B\<	D\<	R\<	B\<	D\<
5	Z*				
6	Z1*				
14	0V				
Shell	0V common				

Digitax ST Plus additional connections

Figure 4-14 Digitax ST Plus terminals view

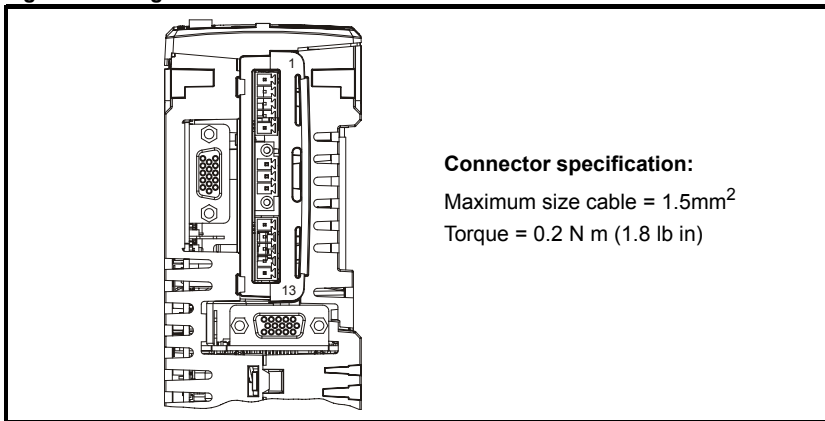

The terminals are numbered from terminal 1 at the top, to terminal 13 at the bottom as per the orientation shown in Figure 4-14. The terminal functions are given in Table 4-5:

Table 4-5 Digitax ST Plus connector details

Terminal	Function	Description
1	0V SC	0V connection for EIA-RS485 port
2	/RX	EIA-RS485 Receive line (negative). Incoming.
3	RX	EIA-RS485 Receive line (positive). Incoming.
4	/TX	EIA-RS485 Transmit line (negative). Outgoing.
5	TX	EIA-RS485 Transmit line (positive). Outgoing.
6	Fieldbus Type A	Fieldbus Type data line
7	Fieldbus Type Shield	Shield connection for Fieldbus Type
8	Fieldbus Type B	Fieldbus Type data line
9	0V	0V connection for digital I/O
10	DI0	Digital input 0
11	DI1	Digital input 1
12	DO0	Digital output 0
13	DO1	Digital output 1

Digitax ST EZMotion additional connections

Figure 4-15 Digitax ST EZMotion terminals view

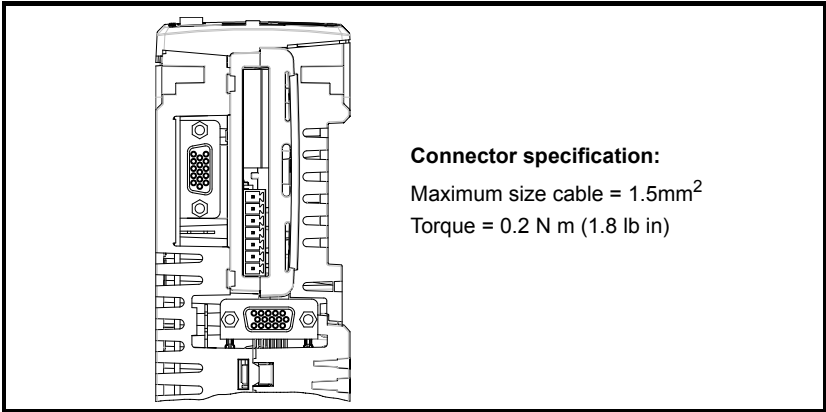
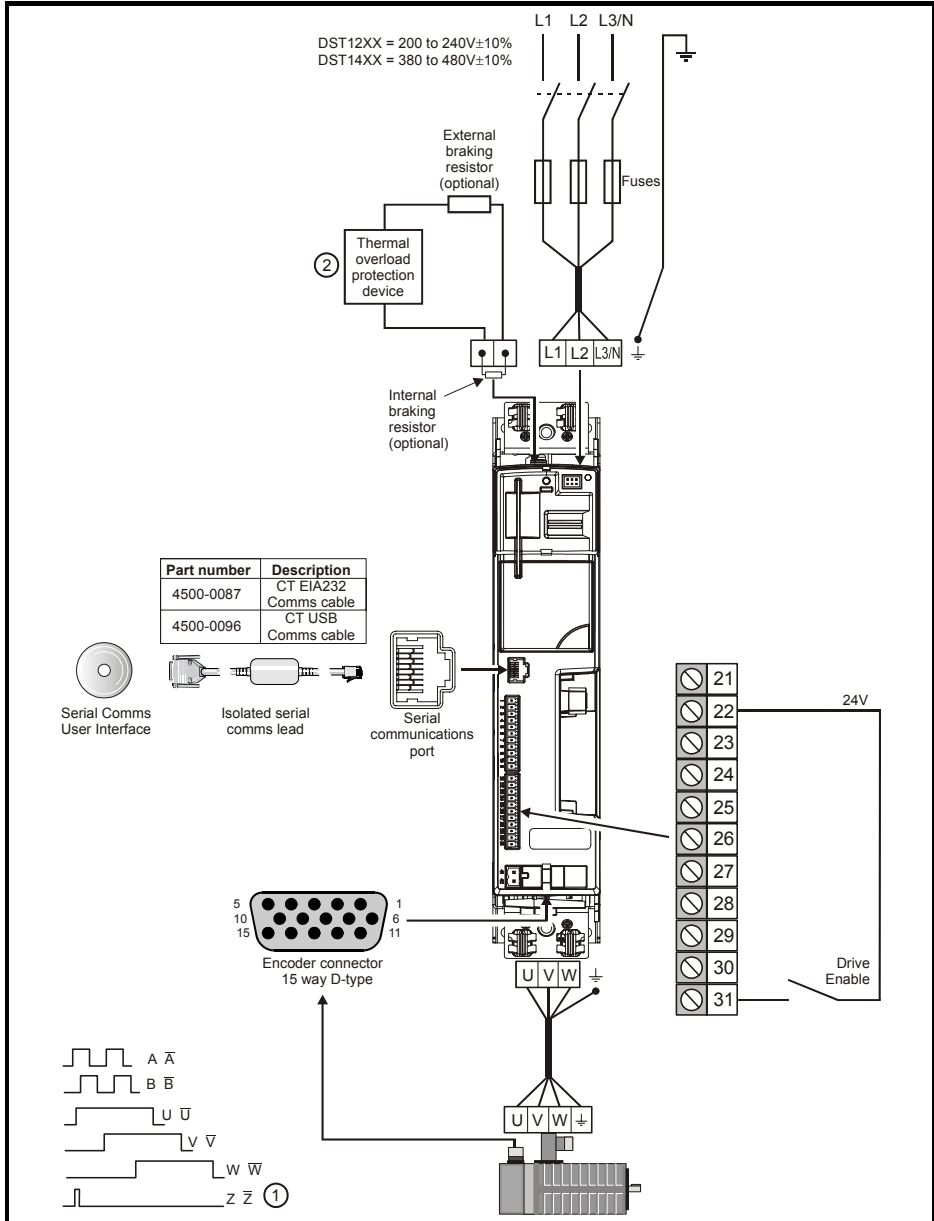

Table 4-6 Digitax EZMotion connector details

Terminal	Function	Description
1	0V common	0V common connection for digital I/O
2	Input 1	Digital input 1
3	Input 2	Digital input 2
4	Input 3	Digital input 3
5	Input 4	Digital input 4
6	Output 1	Digital output 1
7	Output 2	Digital output 2

4.5 Recommended simple start-up

Figure 4-16 Recommended simple start-up via serial communications



1. Marker pulse optional
2. Thermal overload for external braking resistor to protect against fire risk. This must be wired to interrupt the AC supply in the event of a fault. This is not required if the optional internal braking thermistor can be connected internally.



0475-0000-02